

INTRODUCTION

INTRODUCTION

Thank you for purchasing **POWER ACOUSTIK** amplifier.

It is a state - of - the - art product carefully designed and manufactured for vehicle use and has been thoroughly tested to ensure consistent reliable performance.

POWER ACOUSTIK Amplifiers provide high-performance sound reinforcement for your mobile audio equipment. Its versatility enables compatibility with Frequency Dividing Crossovers, and other audio processors in a customized system. The Multimode bridging capabilities allow flexibility in hosting several different speaker configurations.

To achieve optimum performance & longevity, it is highly recommended that you read and apply the advice in this Owners Manual before beginning installation.



FEATURE

FEATURES

CPT1-2200D • CPT1-3200D • CPT1-4000D • CPT1-5500D

- Amplifier type : Class D
- Power Supply : DC-DC PWM Power Supply
- Channel Design : 1 Channel (mono)
- Power Supply Design : MOSFET Power
- Board circuitry : Double sided FR4 PC Board
- Current Protection : 4 way protection
- Adjustable Gain Control : 0.25V ~ 6V
- Crossover : Adjustable Low-pass , Bass boost , Phase shift , Subsonic
- Line outputs : Non - Fading Pre-Amp Output
- RCA Input : NI Plated RCA input Connections
- Connector terminals : NI 2 Gauge input block type Power Terminal & 4 Gauge Out Speaker block type Terminals
- Variable low pass remote dash mounts gain control
- Data link system : Features allows the mono amps to be strapped or bridged via master / slave configuration

SPECIFICATION

SPECIFICATIONS

MODEL	CHANNEL	RMS@40Hzms	RMS@20Hzms	RMS@10Hzms	Max Power	DIMENSIONS (L) x (W) x (H)	FUSE
CPT1-2200D	1	700W mono	950W mono	1300W mono	2200Watt	12" x 9.8" x 2.3"	30A x 2
CPT1-3200D	1	1000W mono	1400W mono	1800W mono	3200Watt	13" x 9.8" x 2.3"	30A x 3
CPT1-4000D	1	1200W mono	1700W mono	2200W mono	4000Watt	16" x 9.8" x 2.3"	30A x 4
CPT1-5500D	1	1700W mono	2500W mono	3200W mono	5500Watt	19" x 9.8" x 2.3"	30A x 5

CONTROLS & FUNCTIONS

CONTROLS & FUNCTIONS

CPT1-2200D • CPT1-3200D • CPT1-4000D • CPT1-5500D

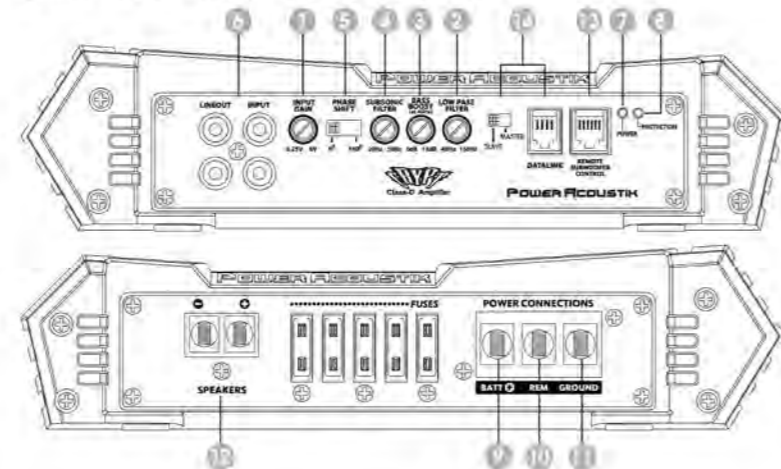

CONTROLS & FUNCTIONS

CONTROLS & FUNCTIONS



This control adjusts the amplifier's input sensitivity. Input sensitivity is variable from 250 Millivolts to 6 volts. Clockwise increases sensitivity. Counterclockwise decreases sensitivity. The amplifier can be driven to full power with a wide range of signal levels. A lower signal level will require increased sensitivity for full power. A higher signal level will require decreased sensitivity. Avoid setting sensitivity lower than necessary as this would introduce unwanted distortion.



Variable Low-Pass Filter :
Adjust variable crossover frequency with control as desired. The amplifier input circuit filters out everything above the frequency selected, so only the deepest bass notes are amplified.



The 'BASS BOOST' function can be selected to increase low frequency response output, or decrease frequency response output.



Variable Subsonic Filter (20Hz - 50Hz)
The Subsonic Filter will roll off all of the unwanted frequencies below 20Hz - 50Hz. This will allow the amplifier to use that wasted power on the audible bandwidth.

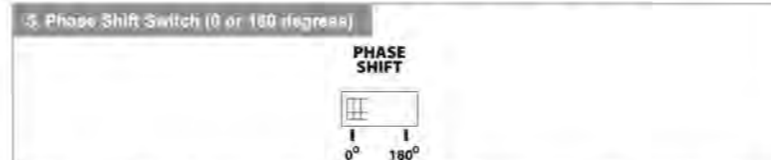

Allows you to change the phase of your subwoofer from 0 to 180 degrees to help compensate for timing differences between drivers.

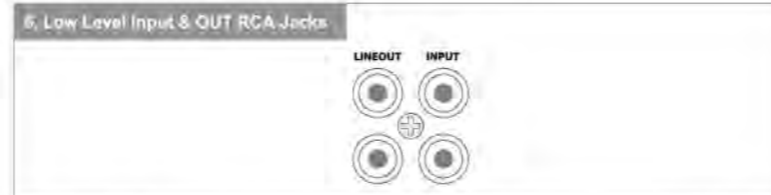

These inputs are for signal cables from the source. Always use high quality shielded RCA cables. The LINE OUT allows you to build multiple amplifier systems without having to use splitter cords to distribute the signal. Now it is simply a matter of bringing one set of RCAS into the first amplifier, then using the line out RCA jacks as the feed to the next amplifier.



Power : This Green LED will illuminate when the amplifier is turned "ON". If it fails to illuminate, check the power connections to the amplifier and fuses.



Protection : The amplifier protection circuitry will disable the amplifier ; if input overload, short circuit or extremely high temperature conditions are detected. When the protection mode is in operation, the LED indicator on the side panel will be illuminated, indicating the amplifier has gone into a self-preservation mode.

If you observe that the Protection LED is lit, please check the system carefully to determine what has caused the protection circuit to engage. The amplifier can be reset by turning the remote power off and then on again. If the amplifier shuts down due to a thermal overload condition, please allow it to cool down before restarting. If the amplifier shuts down because of an input overload or short circuit, be sure to repair these conditions before attempting to power up the amplifier again.

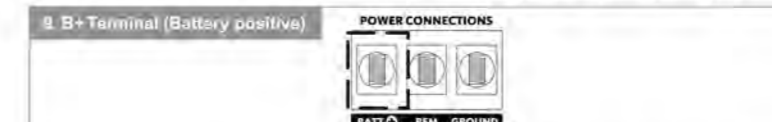

Due to the power requirements of the Amplifier, this connection should be made directly to the positive(+) terminal of battery. For safety measure, install an in line fuse holder (not included) as close to the battery positive(+) terminal as possible with an ampere rating : not to exceed total value of fuses on AMP.

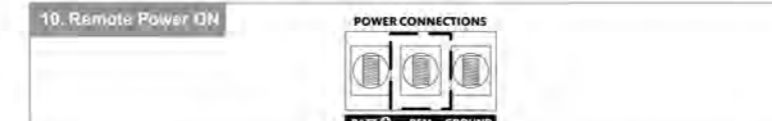

In between the power and ground is remote turn on terminal. This terminal must be connected to a switched +12 Voltage source. You need to use at least 18 gauge to connect remote turn on.

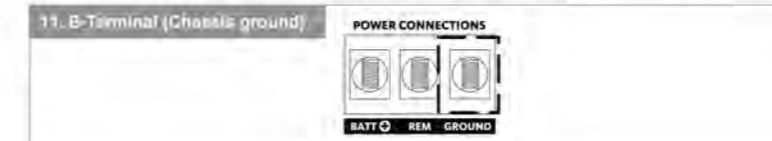

To avoid unwanted ignition noise caused by ground loops, it is essential that the Amplifier be grounded to a clean, bare, metal surface of the vehicles chassis.
Note : GROUND WIRE SHOULD NOT BE EXTENDED MORE THAN 3FT (1METER) IN SOME CASES !

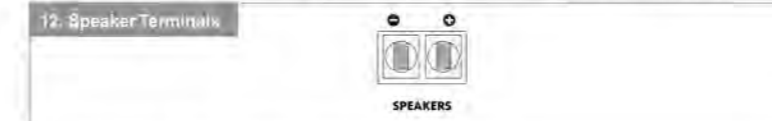

You need to use at least 12 gauge to connect speaker.

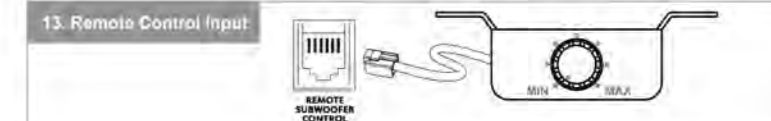

Remote Bass Boost Control : This control adjusts the Bass Boost gain for the amplifier's speaker output (0 ~ +18dB)
* Packed product can be different from the photograph.

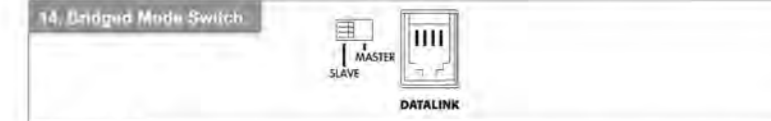

*Master Mode
For bridging into a single speaker load , to do this you must utilize the MASTER / SLAVE switch settings. For the MASTER amplifier , set the switch setting to MASTER. This will route the signal through RCA to the other (slave) amplifier. On the slave amplifier set this switch to the SLAVE position. Refer to Auxiliary Output Configuration section of this guide. Set the PHASE switch on the slave amp, move the phase switch from 0 to 180 , exactly opposite of the master amp. Refer to the Phase switches section of this guide.

*Slave Mode
On the slave amplifier be sure to turn off all crossovers. For the speaker connections , connect the positive (+) speaker lead from the speaker to the positive (+) speaker terminal of the master amplifier. On the negative (-) speaker connection , take the negative (-) speaker terminal of the master amplifier and connect it directly to the negative (-) speaker terminal of the slave amplifier. The remaining positive (+) speaker terminal of the slave amplifier must be connected to the negative (-) speaker lead from the speaker. The impedance of the speaker must not exceed 2Ω .
NOTE : For best results , connect both negative speaker terminals on the master amp to both negative terminals on the slave amp using at least 12 AWG cables.

PLANNING & MOUNTING YOUR SYSTEM

PLANNING & MOUNTING YOUR SYSTEM

The mounting position of your Amplifier will have a great effect on its ability to dissipate the heat generated during normal operation. Under normal conditions, the heatsink will dissipate sufficient heat to avoid thermal shutdown. However please do not install the amplifier in a wooden box or similar device, as this will prevent heat dissipation into the atmosphere.

Temperatures in car trunks have been measured as high as (155°F) in the summer time. Since the thermal shut-down point for the amplifier is (158°F) it is easy to see that it must be mounted for maximum cooling capability. To achieve maximum advantage of convection air flow in an enclosed trunk, mount the amplifier in a horizontal position.

Cooling requirements are considerably relaxed when mounting inside the passenger compartment since the driver will not often allow temperatures to reach a critical point. Floor mounting under the seat is usually satisfactory as long as there is at least 1 inch of clearance (2.54cm) above the Amplifier's fins for ventilation.

- Select a suitable location that is convenient for mounting, is accessible for wiring, and has ample room for air circulation and cooling.
- Use the amplifier as a template to mark the mounting holes. Remove the Amplifier and drill holes. Use extreme caution, inspect underneath surface before drilling!
- Secure the Amplifier using the screws provided.

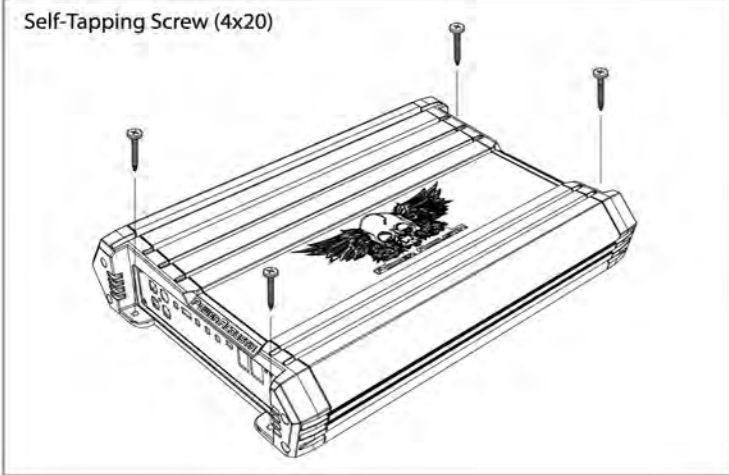

WIRING DIAGRAM

WIRING DIAGRAM

CPT1-2200D • CPT1-3200D • CPT1-4000D • CPT1-5500D

Mono mode

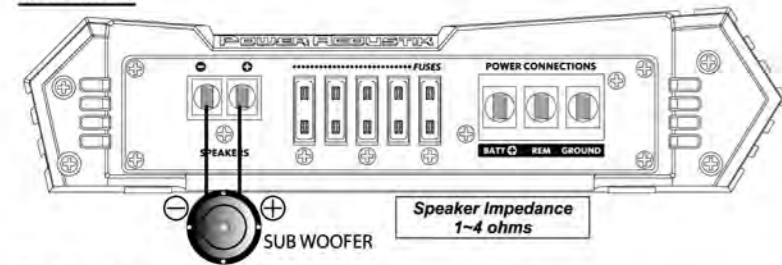

Bridging two Amplifier's

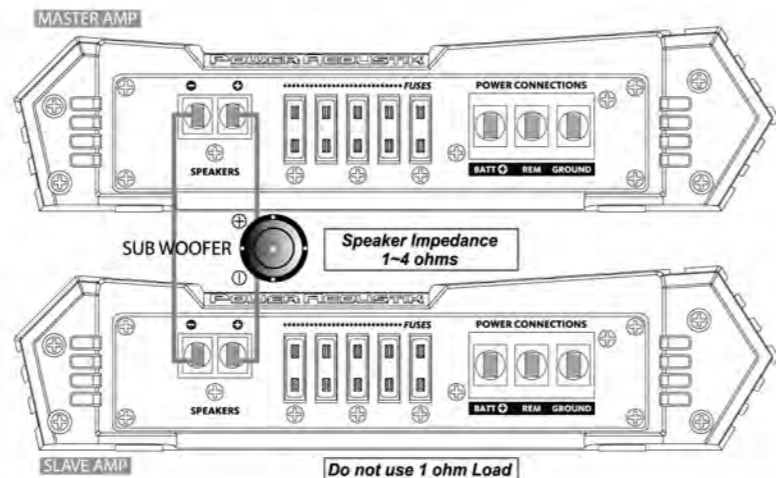
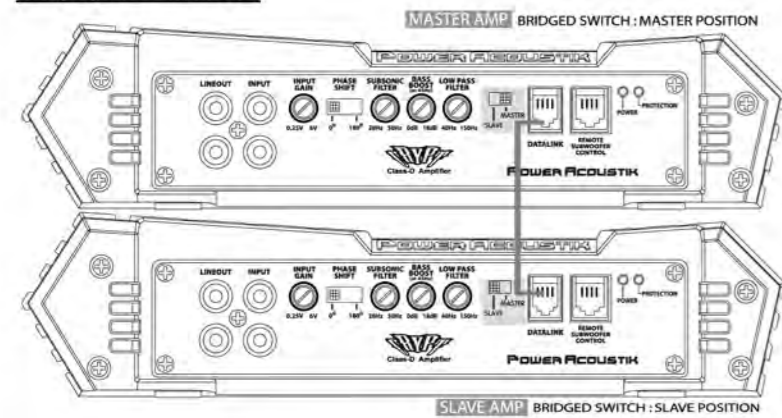

ADJUSTING & TUNING

TURNING ON THE AMPLIFIER

The amplifier automatically turns on a few seconds after you turn your vehicle's ignition switch to ACC or ON or turn on your auto sound system, depending on how you wired the system. The POWER Indicator on the top of the amplifier lights when the amplifier is on.

Important: Your amplifier requires 30 amps or more of power from your vehicle's battery during operation. To protect your battery from discharging, do not operate the amplifier unless your vehicle is running.

ADJUSTING THE AUDIO LEVEL

For the best performance, you must set GAIN(MIN/MAX) on the side of the amplifier to adjust the level of the audio signals that enter the amplifier.

1. Use a screwdriver to turn GAIN(MIN/MAX) fully counterclockwise to MIN.
2. Turn the auto sound system's volume control to about one-third of its full range.
3. Adjust GAIN(MIN/MAX) to a comfortable listening level.
4. Turn up the auto sound system's volume control until the sound begins to distort. Then immediately turn the volume down to a point just before where the distortion began.

Caution: Never turn up the auto sound system's volume control more than needed to adjust the audio level, more than two thirds of its maximum volume.

5. Adjust GAIN(MIN/MAX) until the sound is at the maximum level you want the amplifier to produce.
6. Adjust the auto sound system's volume control to a comfortable listening level.

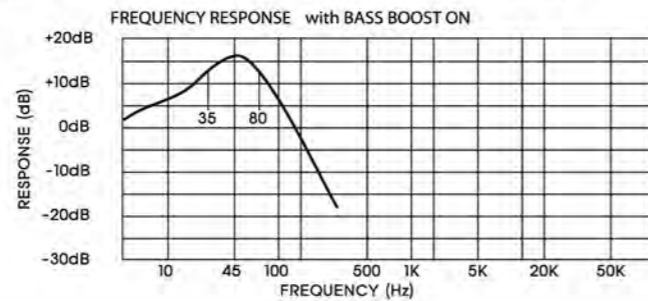

NOTE: Raising the Bass Frequency allows higher frequencies to reach the bass speakers centered around 45Hz. This "BUMP" can have a dramatic effect on the bass system's apparent volume. Use caution! When adjusting this control as serious subwoofer damage may result from overpowering or overexcursion.

TROUBLE SHOOTING & WARNING

TROUBLE SHOOTING

SYMPTOMS	CHECK	REMEDY
NO SOUND	Is the power LED illuminated? (NO)	Check all fuses to amplifier. Be sure Turn-on lead is connected. Check signal leads. Check gain control. Check Tuner/Deck volume level. Clean contacts on fuse holders.
	Is the Diagnostic LED illuminated? (YES)	Check for speaker short or amplifier overheating.
AMP NOT SWITCHING ON	No power to power wire	Repair power wire or connections.
	No power to remote wire with receiver on	Check connections to radio.
	Burnt or broken fuse	Replace fuse
NO SOUND, ON ONE CHANNEL	Check Speaker Leads	Inspect for short circuit or an open connection.
	Check Audio Leads	Reverse Left and Right RCA inputs to determine if the problem is occurring before the amp.
AMP TURNING OFF MEDIUM/HIGH VOLUME	Check Speaker load impedance	Be sure proper speaker load impedance recommendations are observed. (If you use an ohmmeter to check speaker resistance, please remember that DC resistance and AC impedance may not be the same.)
PROTECTION LAMP ON	Shut down	Turn radio down. Wait for AMP to cool
	Speaker wires shorted	Separate speaker wires and insulate

WARNING

Investigate the layout of your automobile through before drilling or cutting any holes. Take care when you work near the gas tanks, lines, or hydraulic lines, and electrical wiring. Don't use power amplifier without securely mounting it. Attach this system securely to the automobile to prevent damage, particularly in the event of an accident. Don't mount this system so that the wire connections are unprotected or are subject to pinching or damage from nearby objects. The +12V DC power wire must be fused at the battery positive terminal connection. Before making or breaking power connections at this system power terminals, disconnect the +12V wire at the battery end. Confirm your radio/cassette player and/or other equip is turned off while connecting the input jacks and speaker terminals. If you need to replace the power fuse, replace it only with a fuse identical to that supplied with the system. Using a fuse of different type or rating may result in damage to this system which isn't covered by the warranty.



POWER ACOUSTIK



Owner's Manual

Mono Digital Amplifier

- CPT1-2200D
- CPT1-3200D
- CPT1-4000D
- CPT1-5500D