



POWER ACOUSTIK

12.34

22:14:34

OWNER'S MANUAL



POWER ACOUSTIK

STAX1250/2 STAX1800/2
STAX2200/2 STAX1200/4 STAX1600/4 STAX2300/4
STAX2000/1D STAX4000/1D STAX5500/1D



INTRODUCTION

Power Acoustik amplifiers provide high-performance sound reinforcement for your mobile audio equipment. Its versatility enables compatibility with optional Equalizers, Frequency Dividing Crossover Networks, and other audio processors in a customized system. The Multi-Mode bridging capabilities allow flexibility in hosting several different speaker configurations.

To achieve optimum performance, it is highly recommended that you read this Owners Manual before beginning installation.

WARNING

High powered audio systems in a vehicle are capable of generating "Live Concert" high levels of sound pressure. Continued exposure to excessively high volume sound levels may cause hearing loss or damage. Also, operation of a motor vehicle while listening to audio equipment at high volume levels may impair your ability to hear external sounds such as; horns, warning signals, or emergency vehicles, thus contributing to a potential traffic hazard. In the interest of safety, Power Acoustik recommends listening at lower volume levels while driving.

TABLE OF CONTENTS

PLANNING YOUR SYSTEM	3
WIRING CONNECTION	4, 5
PANEL LAYOUT	6, 7
CONTROL FUNCTIONS	8-10
SPEAKER CONNECTION MONO CHANNEL	11-14
2 CHANNEL	15, 16
4 CHANNEL	17-19
TROUBLE SHOOTING GUIDE	20
SPECIFICATION	21
WARNING	22

PLANNING YOUR SYSTEM

Before beginning the installation, consider the following:

1. Do you plan to add additional mobile electronics equipment in the future?
If you plan to expand your system by adding other components sometime in the future, ensure adequate space is left and cooling requirements are met.

2. Should you use high or low level inputs?

Your Amplifier has been designed to accept Low-Level(*Pre-Amp outputs from your radio*) source signal. If your radio/source is equipped with Pre-Amp outputs, it is possible to utilize them to drive the Amplifier and the 2 front speakers. Then, use the built-in power of your radio to drive the 2 rear speakers.

3. Are your components matched?

The RMS power rating of your speaker(s) must be equal or greater than the RMS power rating of your amplifier. Your speaker(s) also must be 2 - 8 Ohms impedance for stable amplifier operation. Impedance information is normally printed on the speaker basket or magnet.

4. Where will the amplifier be installed?

Consider both the length of your leads, and routing when determining the mounting location. It is best to run power and RCA wiring on opposite sides of the vehicle to prevent induced noise. Pre-amp input jacks require a length of high quality shielded male to male RCA patch cord.

CONNECTING THE POWER (Fig.1,2)

CAUTION:

AS A PRECAUTION, DISCONNECT THE POWER WIRE FROM THE BATTERY WHILE MAKING THE POWER AND GROUND CONNECTIONS TO THE AMPLIFIER.

4/8 GAUGE (Thicker if planning for additional Amplifiers) wire is recommended for both the power and ground wires. 12 Gauge, for the remote turn-on wire. Both types are available at most Mobile Audio Dealers or Installation Shop.

(1) Ground : *To Vehicle Chassis*

To avoid unwanted ignition noise caused by ground loop, it is essential that the Amplifier be grounded to a clean, bare, metal surface of the vehicle's *Chassis*

NOTE :

GROUND WIRE SHOULD NOT BE EXTENDED MORE THAN 3 FT. (1 METER).

(2) +12 Volt (Fused) Constant Power: *To Battery (+)*

Due to the power requirements of the Amplifier, this connection should be made directly to the positive (+) terminal of battery. For safety measures, install an in-line Fuse Holder (not included) as close to the battery positive (+) terminal as possible with an ampere rating; not to exceed total value of fuses in Amp.

(3) Remote Turn-On Input: *To remote turn-on output of Car Stereo*

This Amplifier is turned "ON" remotely when the vehicle's stereo is turned "ON".

NOTE :

IF YOUR RADIO DOES NOT HAVE A +12 VOLT OUTPUT LEAD WHEN THE RADIO IS TURNED ON, THE "REMOTE" TERMINAL ON THE AMPLIFIER CAN BE CONNECTED TO VEHICLE'S ACCESSORY CIRCUIT THAT IS LIVE WHEN THE KEY IS "ON".

[Fig. 1] STAX 1250/2, 1800/2, 2200/2, 1200/4, 1600/4, 2300/4, 2000/1D, 4000/1D

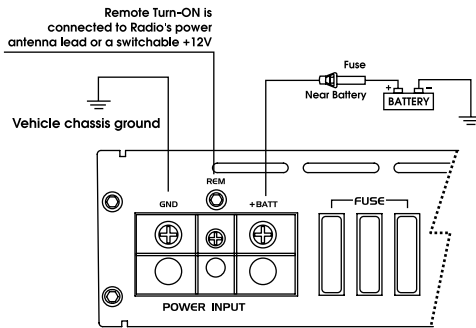

[Fig. 2] STAX 5500/1D

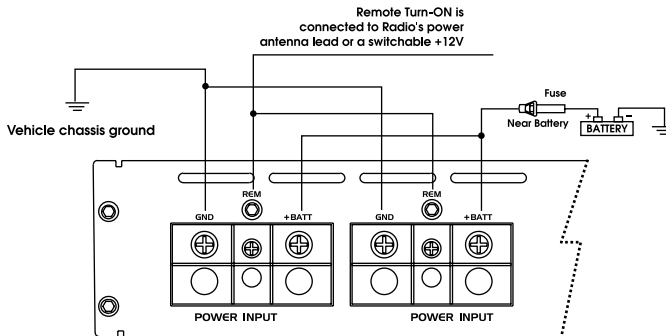

PANEL LAYOUT

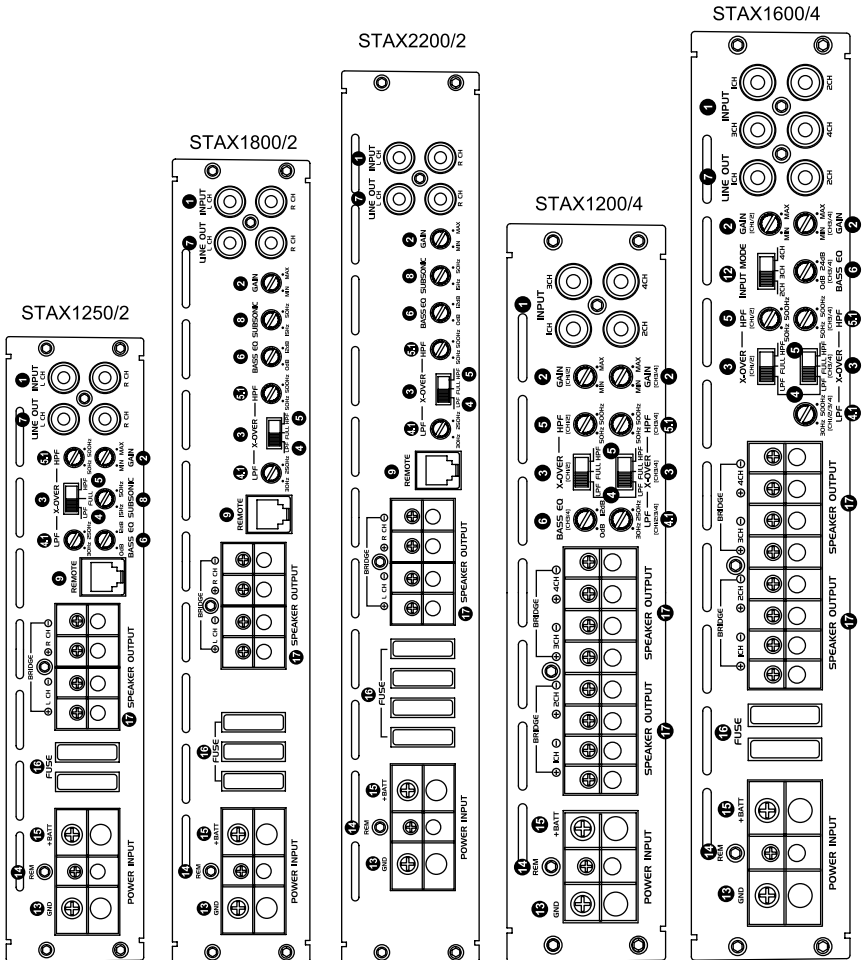

CONTROL FUNCTIONS

1. RCA input jacks

These RCA input jacks are for use with source units that have RCA or Line level outputs. A source unit with a minimum level of 200mV is required for proper operation. The use of high quality twisted pair cables is recommended to decrease the possibility of radiated noise entering the system.

2. GAIN Control

The level control will match the amplifiers sensitivity to the source units signal voltage. The Operating range is 200mV minimum to 6V maximum.

CAUTION: Do not run the amplifier in high volume for long time, otherwise the loudspeakers will be damaged.

3. Full pass x-over switch

When the switch is in the "Full" position, the full range is bypassed.

4. Low pass x-over switch

When the switch is in the "LPF" position, frequencies lower than the low pass frequency setting are passed.

4.1 Low pass x-over frequency control

This control is used to select the desired low pass x-over frequency.

STAX1250/2, 1800/2, 2200/2, 1200/4, 1600/4, 2300/4 : The frequency can be adjusted between 30Hz and 250Hz.

STAX2000/1D, 4000/1D, 55001D : The frequency can be adjusted between 40Hz and 200Hz.

5. High pass x-over switch

When the switch is in the "HPF" position, frequencies higher than the high pass frequency setting are passed.

5.1 High pass x-over frequency control

This control is used to select the desired high pass x-over frequency.

STAX1250/2, 1800/2, 2200/2, 1200/4, 1600/4, 2300/4 : The frequency can be adjusted between 50Hz and 500Hz.

6. Bass EQ

STAX1250/2, 1800/2, 2200/2, 1200/4, 1600/4, 2300/4 : The boost can be adjusted between 0dB to 12dB.

STAX2000/1D, 4000/1D, 55001D : The boost can be adjusted between 0dB to 18dB.

7. Auxiliary outputs

The Auxiliary outputs offer Power Acoustik amplifiers easy, unlimited system expansion. Route RCA's from the line out of the first amplifier to the line input of a second amplifier when using a single source output.

CONTROL FUNCTIONS

8. SUBSONIC

STAX1250/2, 1800/2, 2200/2 : The frequency can be adjusted between 15Hz and 50Hz.
STAX2000/1D, 4000/1D, 5500/1D : The frequency can be adjusted between 20Hz and 50Hz.

9. REMOTE

Controls the subwoofer amplifier gain, from a remote location for ease of adjustment during listening.

Warning: Do not connect a level control knob from other manufacturers to the Remote Sub Level Control of any amplifier. Even though the connectors fit properly, the control knob and connector pin positions may be different and the amplifier will be damaged.

10. PHASE[STAX2000/1D, 4000/1D, 5500/1D]

0° or 180° selectable for switching the phase of the output to the woofer.

11. MASTER/SLAVE MODE[STAX2000/1D, 4000/1D, 5500/1D]

Controls whether the amplifier is a slave or master when connected in combined amplifier configurations. (Refer to the Master Mode section of this guide.)

All of the controls will be adjusted by the "Master" amplifier.

-Slave mode : To be switched " Slave mode" when linking one amplifier with another amplifier.

-Master mode : To be switched " Master mode" when only using this single amplifier.

12. INPUT MODE[STAX1600/4, STAX2300/4]

Selects 2, 3 or 4 channel operation(FIG. 1)

13. GND

Connect this terminal directly to the sheet metal chassis of the vehicle, using the shortest wire necessary to make this connection. Always use wire of the same gauge or larger than the (+)12 volt power wire. The chassis connection point should be scraped free of paint and dirt. Use only quality crimped and/or soldered connectors at both ends of this wire.

Warning : Do not connect this terminal directly to the vehicle battery ground terminal or any other factory ground points.

14. Remote Turn On

This terminal turns on the amplifier when (+)12 volt is applied to it. Connect it to the remote turn on lead of the head unit or signal source.

15. (+)12 Volt Power

Connect this terminal through a FUSE or CIRCUIT BREAKER to the positive terminal of the vehicle battery or the positive terminal of an isolated audio system battery.

Warning: Always protect this power wire by installing a fuse or circuit breaker of the appropriate size within 12 inches of the battery terminal connection.

CONTROL FUNCTIONS

16. FUSE

These fuses protect the amplifier against internal electrical damage and are meant to protect the amplifier only. All other power connections should be fused at the source.

STAX1250/2 : 20A X 2 STAX1800/2 : 20A X 3 STAX2200/2 : 25A X 4

STAX1200/4 : 50A STAX1600/4 : 25A X 2 STAX2300/4 : 30A X 3

STAX2000/1D : 40A X 2 STAX4000/1D : 40A X 3 STAX5500/1D : 40A X 5

17. SPEAKERS

Connect subwoofers to these terminals.

18. LED

Will illuminate GREEN to indicate the amplifier is on and operating normally, and will be illuminated RED if the amplifier shuts down due to short circuit, DC offset, or overheating detected by on board protection circuitry

FIG. 1

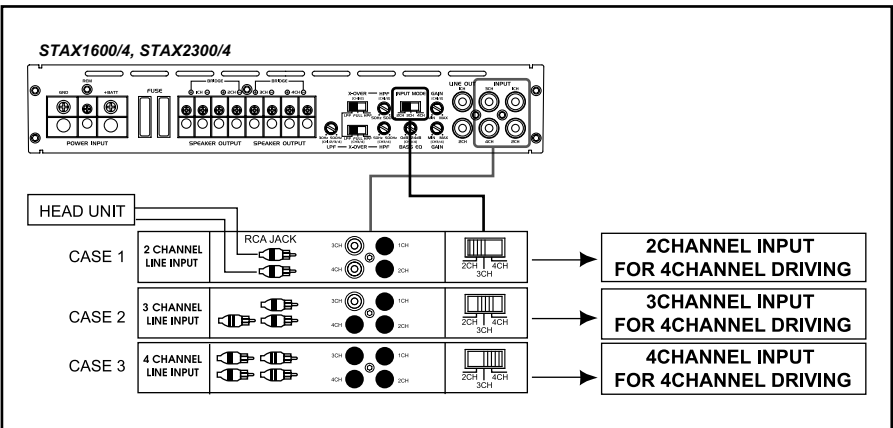
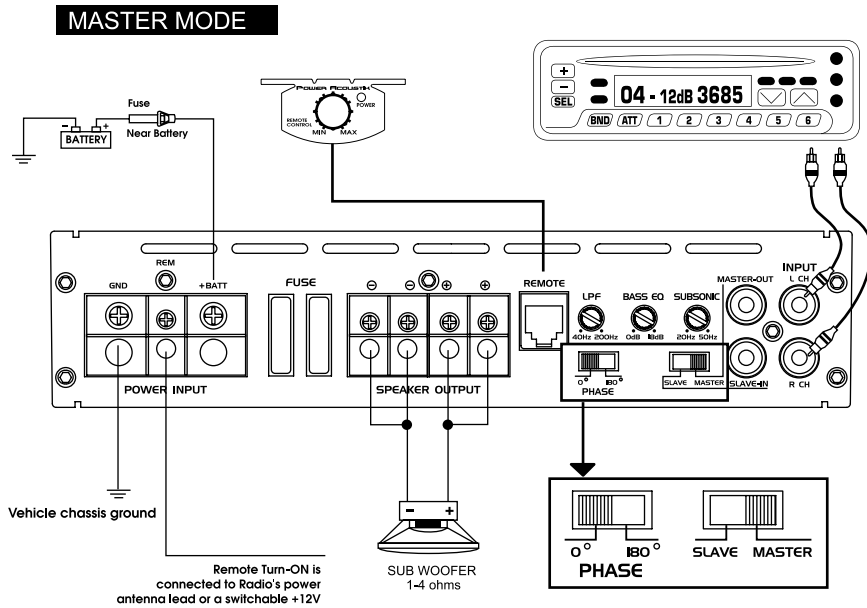

FIG. 2 MASTER MODE CONFIGURATION

STAX 2000/1D, STAX 4000/1D



- 1.Lowest Recommended Impedance is 1ohm mono.
- 2.RCA Inputs are connected to both Left and Right channels
- 3.Gain controls to be set match input source
- 4.Line Output configured for stereo operation

FIG. 3 STRAPPED CONFIGURATION

STAX 2000/1D, STAX 4000/1D

STRAPPED CONFIGURATION

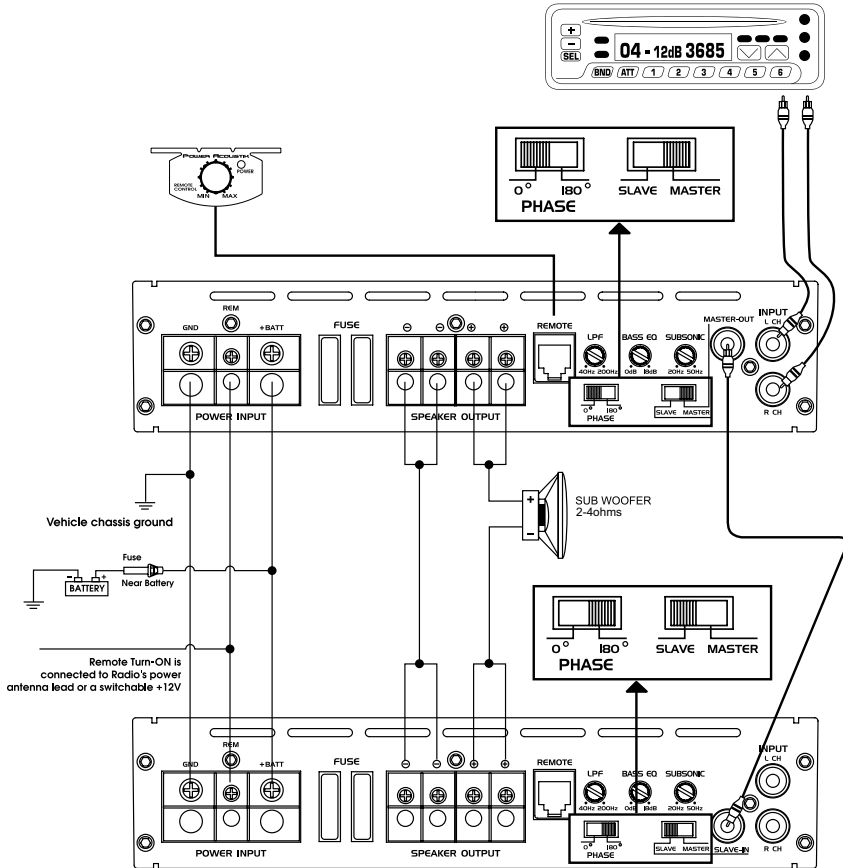

- 1.Lowest Recommended Impedance is 2ohm Stereo
- 2.RCA Inputs are connected to both Left and Right channels
- 3.Gain controls to be set match input source
- 4.Line Output is configured summed bridged which is ideal for subwoofer applications

FIG. 4 MASTER MODE CONFIGURATION
STAX5500/1D

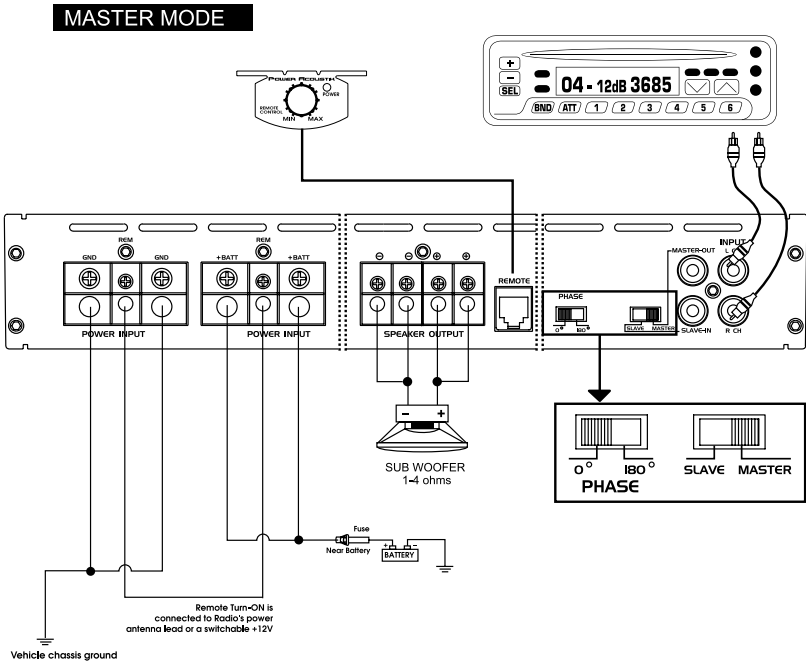

1. Lowest recommended impedance is 1 Ohm Mono.
2. RCA Inputs are connected to both left and right channels.
3. Gain control is to be set to match input source.

FIG. 5 SLAVE MODE CONFIGURATION
STAX5500/1D

STRAPPED CONFIGURATION

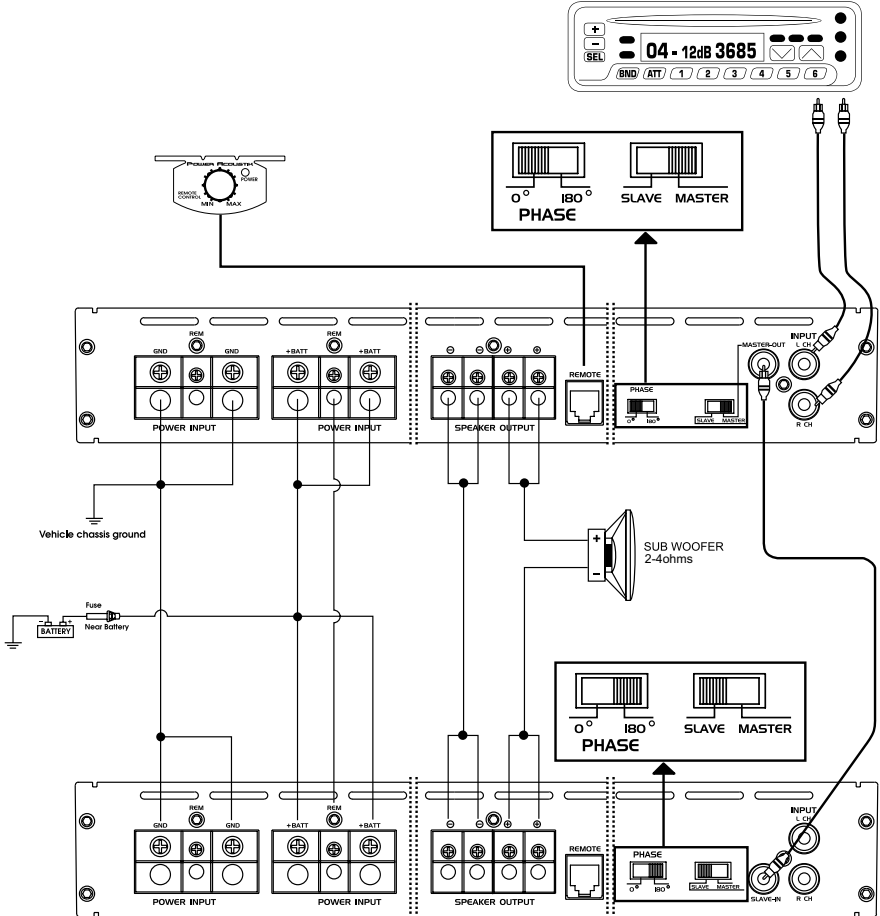

1. All of the controls can be adjusted only in "MASTER" mode amplifier.
2. Lowest recommended impedance is 2 Ohm Mono.
3. RCA Inputs are connected to both left and right channels.
4. Gain control is to be set to match input source.

FIG. 4 2 CHANNEL STEREO CONFIGURATION

STAX1250/2, STAX1800/2, STAX2200/2

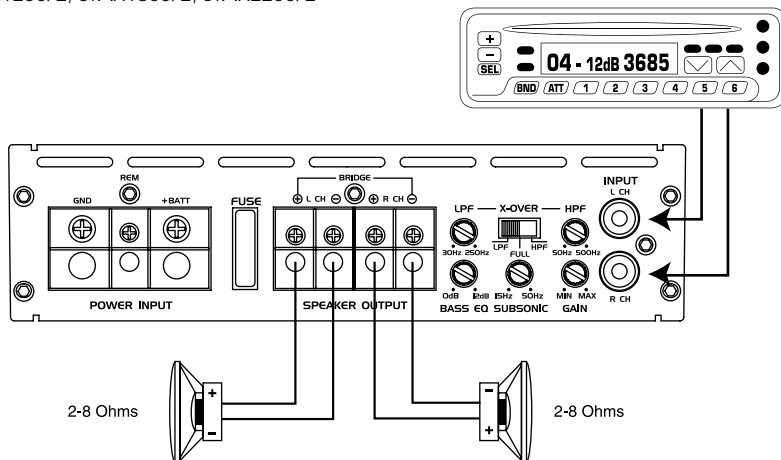

- 1.Lowest Recommended Impedance is 2ohm Stereo
- 2.RCA Inputs are connected to both Left and Right channels
- 3.Gain controls to be set match input source
- 4.Line Output configured for stereo operation

FIG. 5 2CHANNEL BRIDGED CONFIGURATION

STAX1250/2, STAX1800/2, STAX2200/2

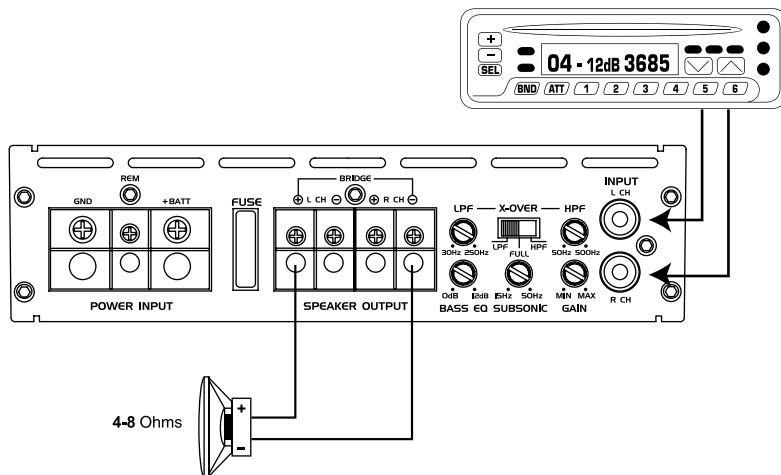

- 1.Lowest recommended impedance is 4ohm bridged mono
- 2.RCA Inputs are connected to both Left &Right channels
- 3.Line Output configured for stereo operation

FIG. 6 2CHANNEL TRI MODE CONFIGURATION
 STAX1250/2, STAX1800/2, STAX2200/2

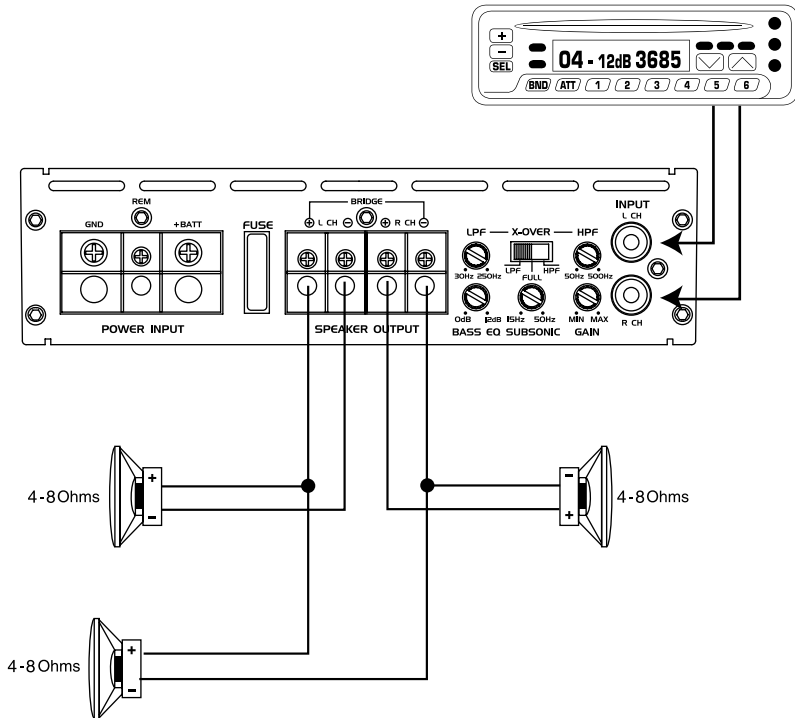

- 1.Lowest Recommended Impedance is 4ohm Stereo
- 2.RCA Inputs are connected to both Left and Right channels
- 3.Output configured for stereo operation

FIG. 7 4CHANNEL STEREO CONFIGURATION
 STAX 1200/4, STAX 1600/4, STAX 2300/4

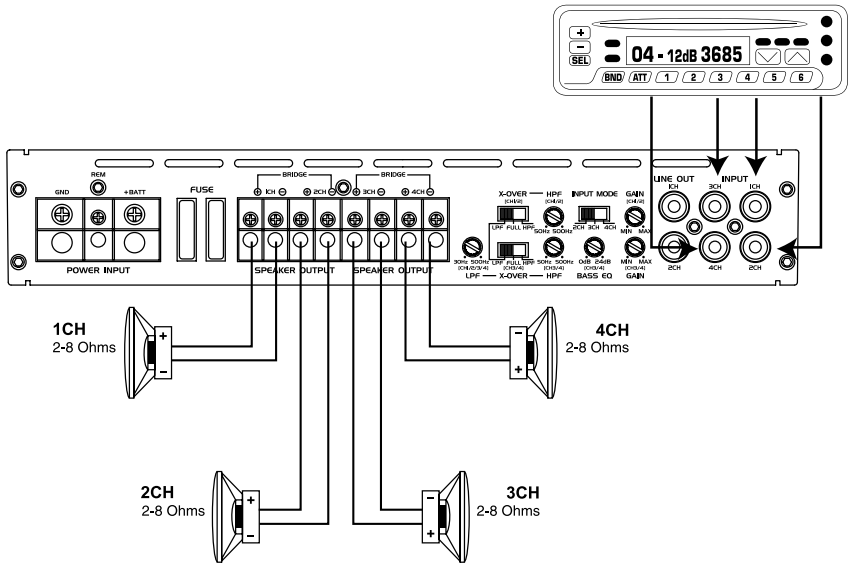

- 1.Lowest Recommended Impedance is 2ohm Stereo
- 2.RCA Inputs are connected to both Left and Right channels
- 3.Gain controls to be set match input source
- 4.Line Output configured for stereo operation

FIG. 8 4CHANNEL BRIDGED CONFIGURATION
 STAX 1200/4, STAX 1600/4, STAX 2300/4

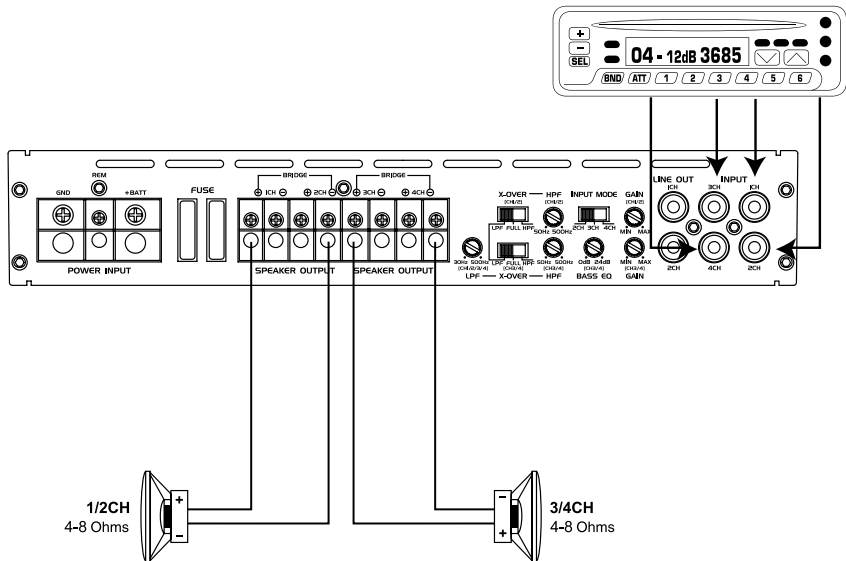

- 1.Lowest recommended impedance is 4ohm bridged mono
- 2.RCA Inputs are connected to both Left &Right channels
- 3.Line Output configured forstereo operation

FIG. 9 4CHANNEL TRI MODE CONFIGURATION
 STAX 1200/4, STAX 1600/4, STAX 2300/4

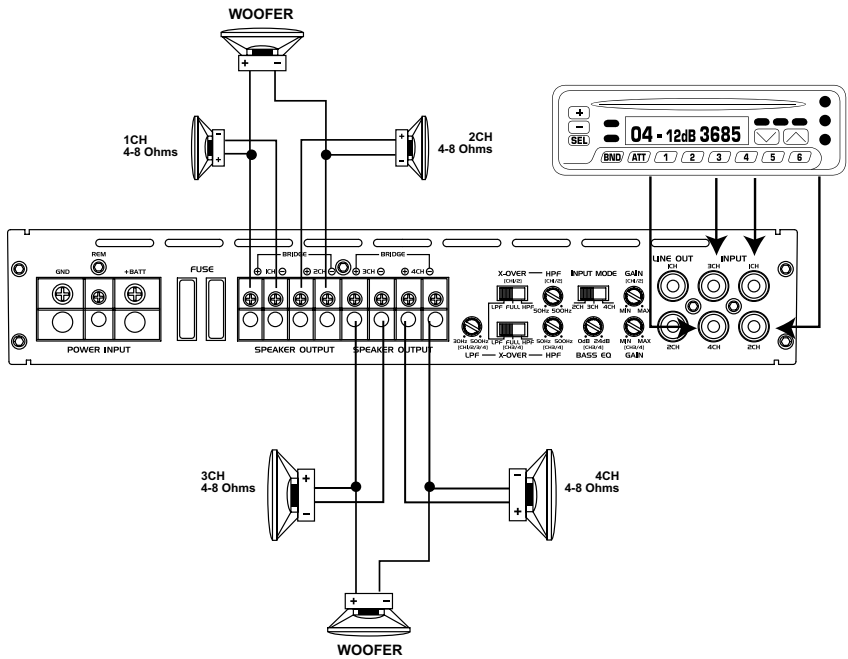

- 1.Lowest Recommended Impedance is 4ohm Stereo
- 2.RCA Inputs are connected to both Left and Right channels
- 3.Output configured for stereo operation

TROUBLE SHOOTING GUIDE

SYMPTOMS	CHECK POINTS	CURE
NO SOUND	Is the power LED illuminated?	Check fuses in amplifier. Be sure Turn-on lead is connected
AMP NOT SWITCHING ON	No power to power wire	Repair power wire or connections
	No power to remote wire with receiver on	Check connections to radio
	Fuse broken	Check fuse
NO SOUND IN ONE CHANNEL	Check speaker leads	Inspect for short circuit or an open connection.
	Check audio input leads	Reverse Left and Right RCA inputs to determine if it is occurring before the amp. Check Tuner/Deck volume level. Clean contacts on fuse holders.
AMP TURNING OFF MEDIUM/ HIGH VOLUME	Check speaker load impedance	Be sure proper speakers are used to ensure impedance recommendations are observed. (If you use an Ohmmeter to check speaker resistance, please remember that DC resistance and AC impedance may not be the same.)

SPECIFICATIONS

MODEL#	STAX1250/2	STAX1800/2	STAX2200/2	STAX1200/4	STAX1600/4
MAXIMUM POWER OUTPUT	1250W	1800W	2200W	1200W	1600W
POWER OUTPUT @4Ohm	220W x 2CH	300W x 2CH	450W x 2CH	100W x 4CH	150W x 4CH
POWER OUTPUT @2Ohm	280W x 2CH	380W x 2CH	540W x 2CH	125W x 4CH	180W x 4CH
BRIDGED POWER	560W x 1CH	760W x 1CH	1080W x 1CH	250W x 2CH	360W x 2CH
THD	0.02%	0.02%	0.02%	0.02%	0.02%
FREQUENCY RESPONSE -1.0dB	10Hz-30kHz	10Hz-30kHz	10Hz-30kHz	10Hz-30kHz	10Hz-30kHz
HPF	50Hz~500Hz	50Hz~500Hz	50Hz~500Hz	50Hz~500Hz	50Hz~500Hz
LPF	30Hz~250Hz	30Hz~250Hz	30Hz~250Hz	30Hz~250Hz	30Hz~250Hz
SUBSONIC FILTER	15Hz~50Hz	15Hz~50Hz	15Hz~50Hz	-	-
BASS EQ	0dB ~ 12dB	0dB ~ 12dB	0dB ~ 12dB	0dB ~ 12dB	0dB ~ 12dB
ADJUSTABLE SENSITIVITY RANGE	0.2V~6V	0.2V~6V	0.2V~6V	0.2V~6V	0.2V~6V
INPUT IMPEDANCE (LOW LEVEL)	10k Ohms	10k Ohms	10k Ohms	10k Ohms	10k Ohms
FUSE	20A x 2	20A x 3	25A x 4	50A x 1	25A x 2
DIMENSION (D x W x H inch)	12.3" x 9.6" x 2.1"	14.7" x 9.6" x 2.1"	17.8" x 9.6" x 2.1"	12.3" x 9.6" x 2.1"	14.7" x 9.6" x 2.1"

MODEL#	STAX2300/4	STAX2000/1D	STAX4000/1D	STAX5500/1D
MAXIMUM POWER OUTPUT	2300W	2000W	4000W	5500W
POWER OUTPUT @4Ohm	180W x 4CH	600W x 1CH	1200W x 1CH	1700W x 1CH
POWER OUTPUT @2Ohm	250W x 4CH	900W x 1CH	1700W x 1CH	2500W x 1CH
POWER OUTPUT @1Ohm	-	1200W x 1CH	2200W x 1CH	3200W x 1CH
BRIDGED POWER	500W x 2CH	-	-	-
THD	0.02%	0.2%	0.2%	0.2%
FREQUENCY RESPONSE -1.0dB	10Hz-30kHz	(-3dB) 20Hz-200Hz	(-3dB) 20Hz-200Hz	(-3dB) 20Hz-200Hz
HPF	50Hz~500Hz	-	-	-
LPF	30Hz~250Hz	40Hz~200Hz	40Hz~200Hz	40Hz~200Hz
SUBSONIC FILTER	-	20Hz~50Hz	20Hz~50Hz	20Hz~50Hz
BASS BOOST	0dB ~ 12dB	0dB ~ 18dB	0dB ~ 18dB	0dB ~ 18dB
ADJUSTABLE SENSITIVITY RANGE	0.2V~6V	0.2V~6V	0.2V~6V	0.2V~6V
INPUT IMPEDANCE (LOW LEVEL)	10k Ohms	10k Ohms	10k Ohms	10k Ohms
FUSE	30A x 3	40A x 2	40A x 3	40A x 5
DIMENSION (D x W x H inch)	17.8" x 9.6" x 2.1"	12.3" x 9.6" x 2.1"	14.7" x 9.6" x 2.1"	17.8" x 9.6" x 2.1"

WARNINGS

Investigate the layout of your automobile thoroughly before drilling or cutting any holes. Take care when to work near the gas tanks, lines, or hydraulic lines, and electrical wiring. Don't use power amplifier unmounted. Attach this system securely to the automobile to prevent damage, particularly in the event of an accident. Don't mount this system so that the wire connections are unprotected or are subject to pinching or damage from nearby objects. The +12V DC power wire must be fused at the battery positive terminal connection. Before making or breaking power connections at this system power terminals, disconnect the +12V wire at the battery end. Confirm your radio/cassette player and/or other equip is turned off while connecting the input jacks and speaker terminals. If you need to replace the power fuse, replace it only with a fuse identical to that supplied with the system. Using a fuse of different type or rating may result in damage to this system which isn't covered by the warranty.