



PowerAcoustik

PPF-4

PPF-5

PPF-6

**PERFECT FIT COMPONENT
SPEAKER SYSTEM
INSTALLATION MANUAL**

Thank you for purchasing a **PowerAcoustik** speaker system. It is a state-of-the-art product carefully designed manufactured for vehicle use, and has been thoroughly tested to ensure consistent and reliable performance.

If you have any question about the installation or operation of your **PowerAcoustik** speaker system which are not answered by this manual, contact your dealer in the first instance.

Precautions

- Before making holes, check the mounting space with supplied template
- To prevent noise pick-up, keep the wiring of this unit away from motors, High-voltage leads and other possible noise, surge.
- To prevent short-circuit, keep all wiring away from moving parts sharp edges.
- Make sure you have carefully read and understood the installation instruction.

Tools required

These are the tools required to complete the basic installation of the **PowerAcoustik** full range series compoents. Additional tools are necessary for more custom work unit.

1. Electric drill with bit
2. Philips screwdriver
3. Flat blade screwdriver
4. Wire Strippers
5. Crimping tool
6. Saber saw, hole saw, or nibbler
7. Utility knife
8. Silicon sealant or weather stripping (optional)
9. Electrical tape

INSTALLATION INSTRUCTIONS FOR TWEETER

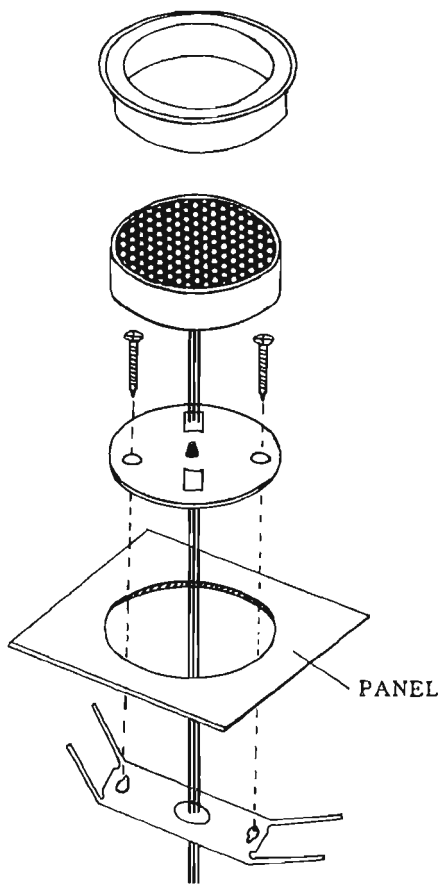

FLUSH MOUNT

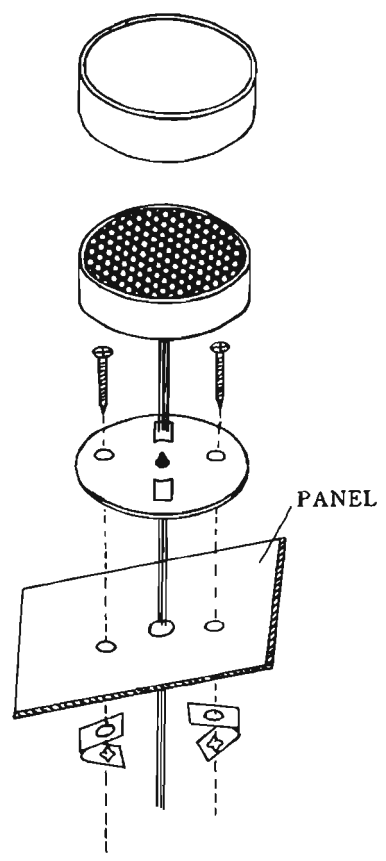

SURFACE MOUNT

CROSSOVER INSTRUCTION (2WAY)

• Connection

Use only the crossover that come with the **PowerAcoustik** full range series speaker system. Use of any other crossover may result in damage to one or more of the components; install under the dash, under the rear package shelf, or in the trunk. However, they should not be located where they will be subjected to moisture; such as in a leaky door. If possible, locate the crossovers closer to the speakers than the amplifier.

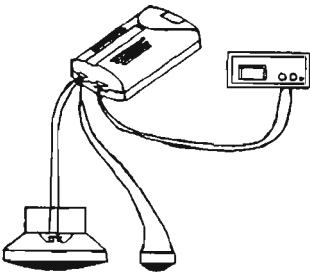

1. Remove the crossover cover to gain access to the scrw holes.
Use your thumb to push and lift one side the cover as shown in the diagram.
Do not attempt to pry the cover off
2. Use the uncovered crossover as a template to mark the two screw holes.
Make sure there is enough clrance on the other side of the mounting surface.
3. Drill two 1/8" pilot holes for the screws and install the crossovers.
4. Cut the pre-run speaker wire to the correct length. Attach spade lugs to the wire and connect to the crossover.
5. Please fix crossover at the proper position, using screws provided as shown in the left figure.

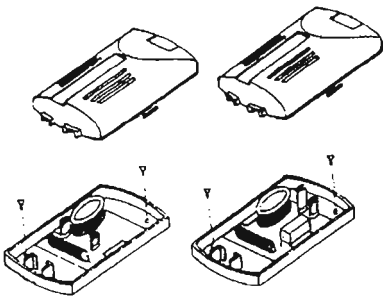

PPF - 4 / PPF - 5 PPF 6

- Mark the opposite end of each wire the same way, but each wire should be marked differently; For example; both ends of the left tweeter wire have one piece of tape and both ends of the left woofer wire have two pieces of tape.
- Route the wires. For Doors; run the wires through factory harnesses or existing holes, if possible. If drilling new holes, file the edges and install rubber grommets to protect the wires against abrasion. For Rear Deck; run the wires along the door sils, lifting and replacing carpet as required

you may have to remove the rear seat to pass wires back to the rear.

WOOFER INSTRUCTION

(PPF-4、PPF-5、PPF-6)

1. Using mounting template for speaker, mark the correct mounting location by a pencil or pen.

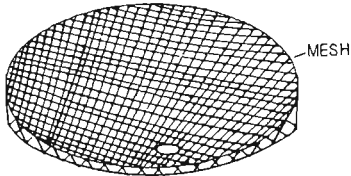

2. Cut out the panel by this marking and drill 4 holes for the mounting bolts to pass through.

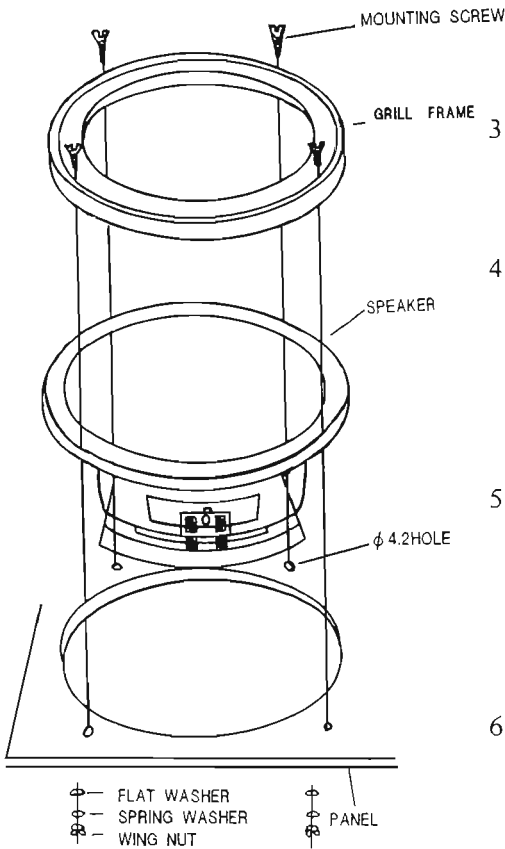

3. Separate the punching metal from the grill frame.
4. Connect the terminal of speaker to car audio correctly by using cord provided.
Caution: Be careful not to misconnect polarity
5. Insert grill frame & speaker Unit in the speaker mounting hole at the rear panel and fix speaker with bolts & screws & nuts provided.

6. Put the punching metal back with the grill frame.